

# TB4CS

## Conductivity sensor

### 4-Electrode

Low maintenance sensor with the widest operation range available (0 to 2000 mS/cm)

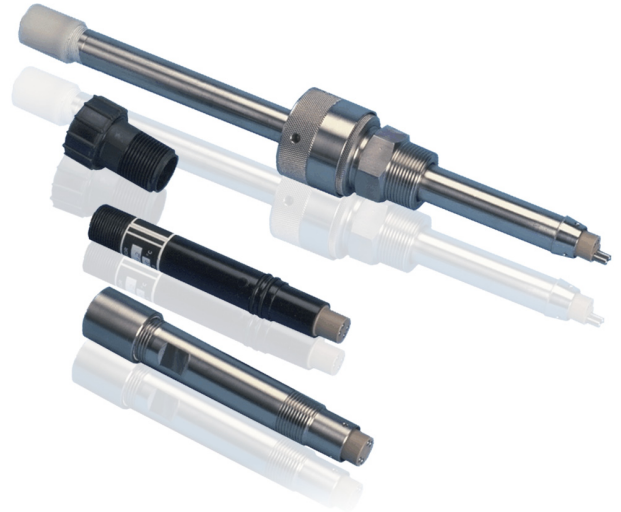

#### 4-electrode measurement

- Increases accuracy, stability, flexibility, and security

#### Resilient

- Sensors capable of withstanding the toughest chemical processes at extreme temperatures and pressures

#### Corrosion resistant stainless steel electrodes

- For all conductivity ranges without polarization

#### Smaller measurement electrodes

- High current densities are permissible due to feedback circuitry and polarization compensation

#### Wide rangeability with excellent linearity

- Compensates for polarization effects

#### Overcome and compensate for fouling effects

- Reduces frequency of cleaning

#### Extent of fouling notification and fouled sensor relay

- Makes it possible for conductivity instrument to notify of dirty sensor condition

#### Rugged construction and materials

#### Installation flexibility

- Inline, Twist-lock, Immersion, Tri-Clamp, Flow-cell, TB18 Safe-TClean Valve & Retractable Hot-Tap

#### Interchangeable measurement tips

#### Suitable for all measurements

- From low to high solution concentrations

## Endura 4-Electrode Conductivity Sensors for Process Monitoring

ABB is the industry leader in advancements resulting in the increased accuracy, dependability, and environmental limits of on-stream conductivity sensors. The conductivity sensor line permits resolutions of 0.001 microsiemens per centimeter, full-scale ranges of one siemen per centimeter, pressure ratings to 2,068 kilopascals (300 psig), and temperature ratings of 200-degrees Celsius (392-degrees Fahrenheit). Group A sensors have a measurement range spanning five decades of conductivity or TDS concentration.

The ABB 4-electrode conductivity system is a patented concept unique in the process industry. It provides ultimate sampling flexibility, sensor reliability, rangeability, and helpful operating and maintenance information. Smart circuitry detects and compensates for the buildup of deposits, and scale and corrosion products on the sensor. It also provides an alarm before the interference becomes so serious as to affect the conductivity signal. The dirty sensor alarm output is a contact closure, a digital signal, or any other easily observed format.

### Anti-Fouling 4-Electrode Circuit

Figure 1 shows the 4-electrode conductivity system which consists of two current electrodes and two potential electrodes, a high impedance amplifier providing feedback to an amplitude-controlled oscillator, a conductivity sensing circuit with associated load resistor and display, and a dirty sensor alarm circuit.

Feedback from the high impedance amplifier causes the oscillator to vary its amplitude output to maintain a constant excitation field, created by the current electrodes in the solution, as sensed by the potential electrodes. The current required to create the excitation field passes through the load resistor and is sensed as a voltage drop by the conductivity sensing circuit. The amount of excitation current required to maintain a constant excitation field in a solution is directly proportional to conductivity. If fouling of the electrodes occurs, the AC potential at the electrodes increases to drive the excitation through the deposits to maintain the constant excitation field. The increase in potential at the current electrodes compensates for the increase in interface resistance at them. The high impedance amplifier draws no current; therefore, the voltage drop across deposits on the potential electrodes is negligible and contributes no significant error.

The dirty sensor alarm circuit measures the oscillator amplitude. The amplitude stays below a predefined threshold during normal operation. If the amplitude exceeds that threshold, the conductivity measuring instrument notifies, via an alarm, readout, or other method, that the sensor needs cleaning.

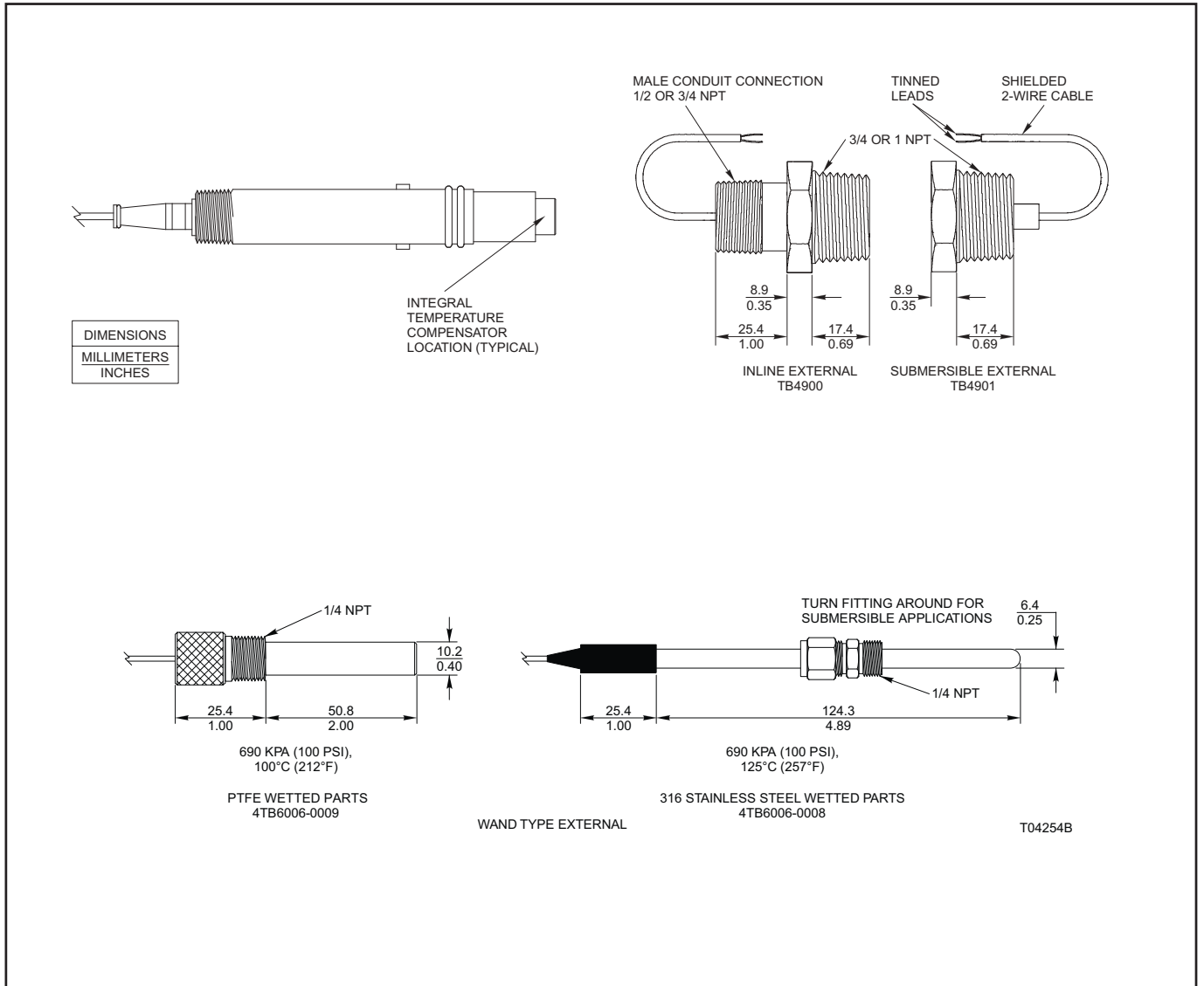

Figure 1. 4-Electrode Conductivity System

## Sensor Groups and Ranges

There are two groups of 4-electrode conductivity sensors. The rangeability of any sensor is defined by the physical structure of the electrodes and the electronic circuitry of the associated instrument. The physical structure of the electrodes determines the sensor cell constant; however, the concept of sensor cell constants is more applicable to two-electrode sensors. Unlike 4-electrode sensors, as manufactured by ABB, the rangeability of two-electrode sensors is restricted by current density and polarization. 4-electrode sensors are not limited by these factors. The result is a virtual dimensionless sensor constant with wide rangeability.

The actual measurement range is determined by the sensor group and the instrument range or range factor in use. All ABB conductivity instruments are multirange types. This provides numerous application options for any sensor and instrument combination.

ABB 4-electrode conductivity sensors are arranged in two groups, loosely adhering to the sensor cell constant structure in the following manner:

- **Group A:** General purpose for zero to 100 to zero to 2,000,000  $\mu\text{S}/\text{cm}$ .
- **Group B:** Low to medium range for zero to 10.00 to zero to 2,000  $\mu\text{S}/\text{cm}$ .

Table 1 provides a list of sensor and ranges.

## Temperature Compensation

ABB conductivity sensors are available with temperature compensators either integral to or separate from them. The type of temperature compensator must be supported by the instrument. AX4 series microprocessor-based instruments accept 3k $\Omega$ , Pt 100 and Pt 1000 temperature compensation. Type TB82EC and TB84EC microprocessor-based instruments have the option of using a 3k $\Omega$  or Pt 100 RTD.

Figure 2 shows the temperature compensators. The effect of temperature on conductivity is significant; therefore, for measurements to be accurate, conductivity must be compensated to a reference temperature (typically 25°C).

## Flow Cells

The flow cell (Fig. 3) is available for both conductivity and pH sensors. It is designed for use with the Endura TB264 Two-Electrode Conductivity Sensors, Endura TB464 4-Electrode Conductivity Sensors, and Endura TB(X)561 pH/ORP Sensors. Multiple inlet and outlet ports provide flexibility with installation, calibration, and mounting configurations. The sensor can be inserted and removed from the flow cell quickly and easily without disconnecting the sensor from the instrument or junction box.

Table 1. Ranges for conductivity instruments

Sensor Groups and Sensors		Measurement Range TB82EC, TB84EC
A	TB451, TB454, TB457, TB461, TB464A, TB468, TB471	0.00-2,000,000 $\mu\text{S}/\text{cm}$ (autoranging)
B	TB452, TB458, TB464B, TB465, TB475	0.00-2,000 $\mu\text{S}/\text{cm}$ (autoranging)

Table 2. Ratings and Mounting Arrangements for Conductivity Sensors

Sensor	Max. Temp.		Max. Pressure <sup>1</sup>		Mounting Arrangement
	$^{\circ}\text{C}$	$^{\circ}\text{F}$	KPag	psig	
TB451, TB452	140	284	689	100	Sterilizable
TB454	100	212	689	100	Twist Lock insertion, submersion
TB457, TB458	175	347	861	125	Sterilizable
TB461, TB465	200	392	1,550	225	Direct insertion, submersion, separate flow cell
			689	100	Ball valve insertion
TB464	200	392	1,378	200	Sterilizable, submersion, separate flow cell, TB18 Safe-T-Clean valve
TB468	100	212	689	100	Direct insertion, submersion
	140	284	275	40	Hot tap, ball valve insertion
TB47	200	392	2,068	300	High pressure retractable hot tap, ball valve insertion

Note 1. Temperature affects maximum allowable pressure. Refer to individual sensor specifications for details.

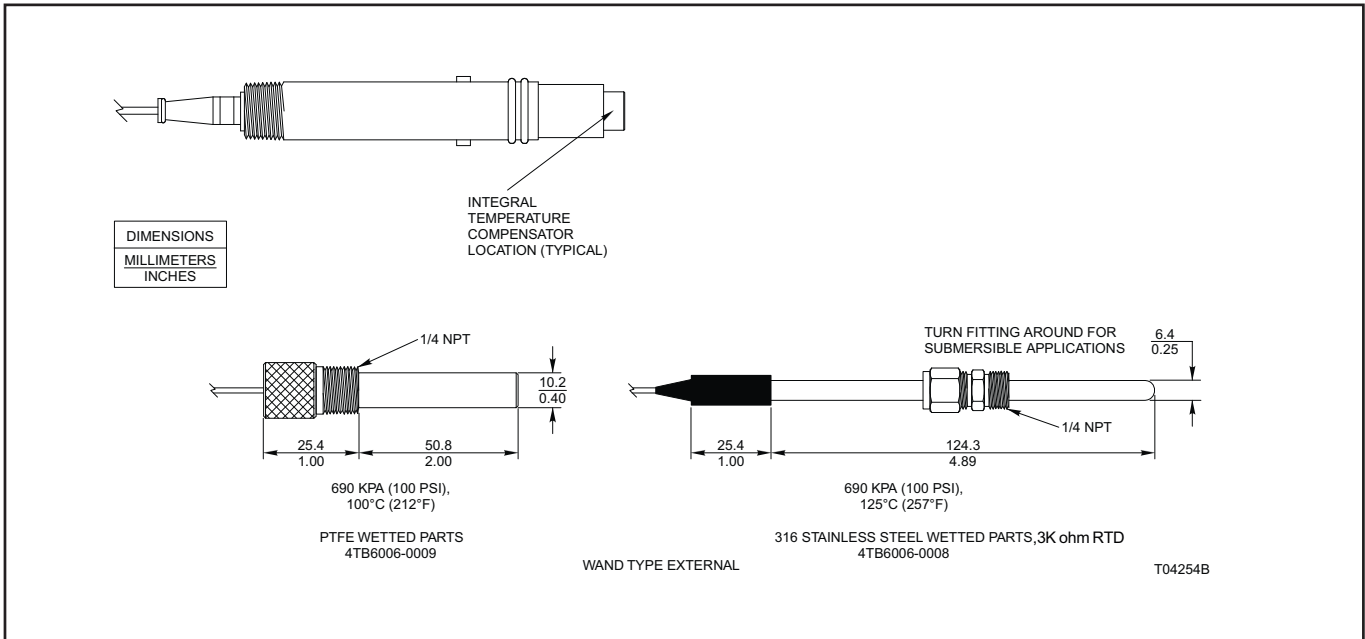

Figure 2. Temperature Compensators

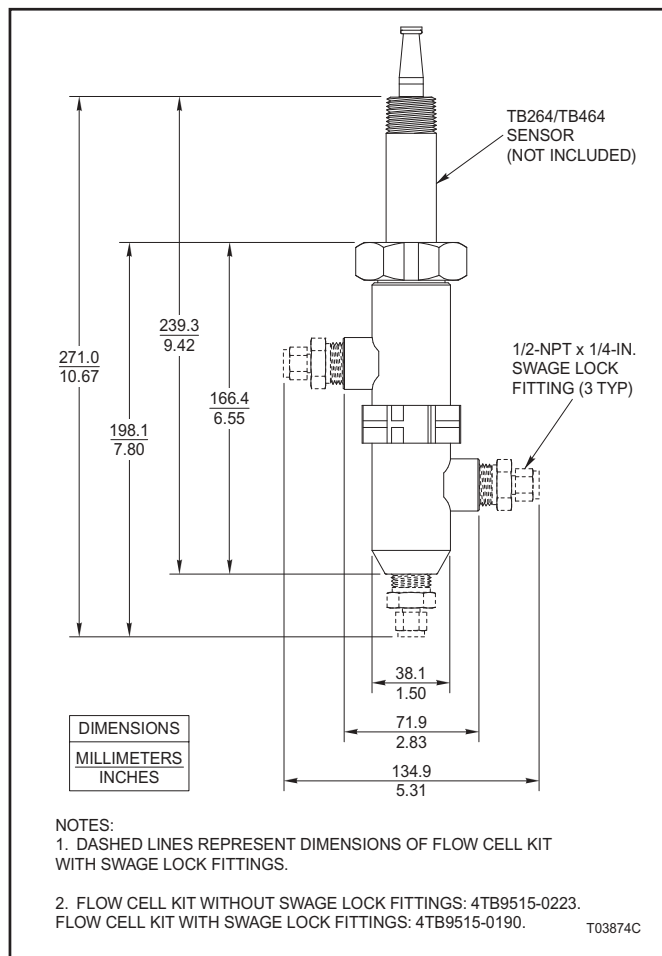

Figure 3. Flow Cell Kits

## Endura TB451 & TB452 Kynar® Sterilizable Tri-Clamp Conductivity Sensors

Endura TB451 & TB452 sensors (Fig. 4) have an integral Tri-Clamp® fitting for use in sanitary services. ABB offers two styles of these sensors. The first is a flush face style that meets the process right at the Tri-Clamp fitting. The second has an extended face designed to meet the process at the end of a Tri-Clamp fitting such as a tee. The extended face type is O-ring sealed to prevent the process solution from getting behind the electrode face where cleaning chemicals will not reach. This style of sensor can be sized to fit either 1.0-inch or 1.5-inch tubing. The flush style can be used with either size.

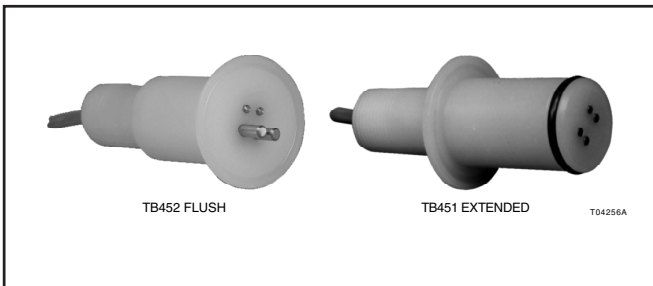

Figure 4. Endura TB451 & TB452 Sensors

## Endura TB451 & TB452 Sensor Specifications

### Application

Food, beverage, brewery, dairy, pharmaceutical

services where process lines must be sterilized and/or chemical or steam cleaning takes place.

### Max. Pressure/Temperature

Max. 689 kPag (100 psig) at 90°C (194°F)  
447 kPag (65 psig) at 121°C (250°F)  
275 kPag (40 psig) at 140°C (284°F) max.

### Materials

Body: Virgin Kynar (PVDF)  
Electrodes: 316 stainless steel  
Internal O-rings: Ethylene propylene

### Special Features

Integral Tri-Clamp flange. Security from crevice formation in process.

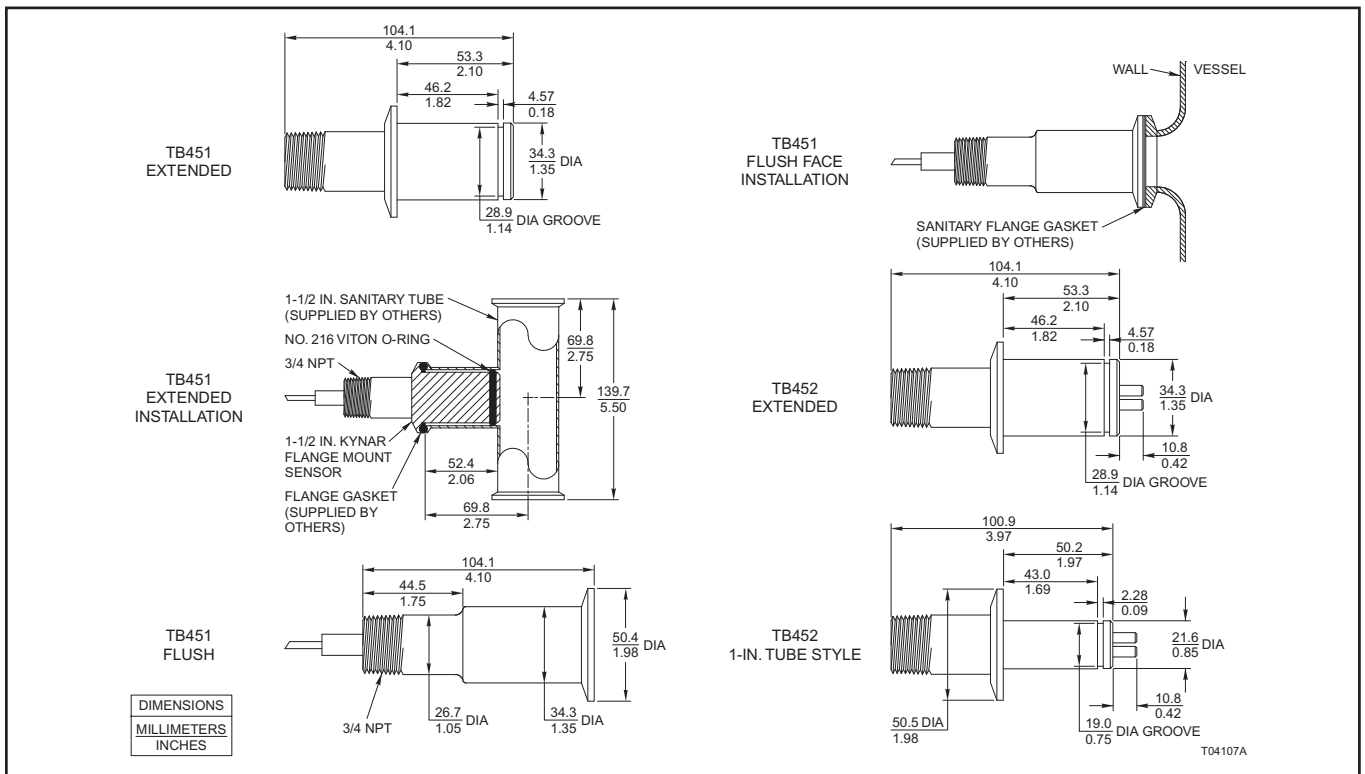

Figure 5. Endura TB451 & TB452 Sensor Dimensions

Variant digit No.		1-5	6	7	8
<b>Endura TB451 Kynar Sterilizable Tri-Clamp Conductivity Sensor</b>					
<b>Range 0 - 2,000,000 <math>\mu</math>S/cm</b>		<b>TB451</b>	X	X	X
<b>Integral Temperature Compensation</b> 3K ohm			E		
<b>Tri-Clamp Style</b>					
Extended style, for 1.5 inch tube, 2 inch flange Tri-Clamp				1	
Extended style, for 1.0 inch tube, 2 inch flange Tri-Clamp				2	
Flush style, for 1.0 or 1.5 inch tube, 2 inch flange Tri-Clamp			2)	3	
<b>Integral Cable Length</b>					
No Cable; Junction Box (4TB5023-0088) Included					0
5 ft (1.5 m)					1
10 ft (3 m)					2
15 ft (4.5 m)					3
20 ft (6 m)					4
25 ft (7.6 m)					5
30 ft (9.1 m)					6
35 ft (10.6 m)					7
40 ft (12.1 m)					8
45 ft (13.7 m)					9
50 ft (15.2 m)					A

2) Flush flange insertion depths: TB451 is 0.80 inches.

**Accessories**

Interconnecting cable (per foot)	4TB3004-0008
Mylar tag	4TB5003-0002
Stainless steel tag	4TB5003-0003
Junction box	4TB5023-0088



	Variant digit No.	1-5	6	7	8
<b>Endura TB452 Kynar Sterilizable Tri-Clamp Conductivity Sensor Range 0 - 2,000 <math>\mu</math>S/cm</b>	<b>TB452</b>		X	X	X
<b>Integral Temperature Compensation</b> 3K ohm			E		
<b>Tri-Clamp Style</b>					
Extended style, for 1.5 inch tube, 2 inch flange Tri-Clamp				1	
Extended style, for 1.0 inch tube, 2 inch flange Tri-Clamp				2	
Flush style, for 1.0 or 1.5 inch tube, 2 inch flange Tri-Clamp			2)	3	
<b>Integral Cable Length</b>					
No Cable; Junction Box (4TB5023-0088) Included					0
5 ft (1.5 m)					1
10 ft (3 m)					2
15 ft (4.5 m)					3
20 ft (6 m)					4
25 ft (7.6 m)					5
30 ft (9.1 m)					6
35 ft (10.6 m)					7
40 ft (12.1 m)					8
45 ft (13.7 m)					9
50 ft (15.2 m)					A

2) Flush flange insertion depths: TB452 is 0.80 inches.

**Accessories**

Interconnecting cable (per foot)	4TB3004-0008
Mylar tag	4TB5003-0002
Stainless steel tag	4TB5003-0003
Junction box	4TB5023-0088

## Endura TB454 Twist-Lock Conductivity Sensor

Endura TB454 sensors (Fig. 6) combine versatility, easy access, and low cost into one compact package. The sensor is suitable for either inline or immersion installations. It fits into a 1-inch NPT receptacle and is inserted with a push and 180-degree twist to lock for inline installations. There is also a Ryton® (PPS) holder with screw cap available. The wide rangeability of this sensor makes it a perfect match for almost all less aggressive conductivity measurements.

## Endura TB454 Sensor Specifications

### Applications

Cooling towers, water and waste monitoring, packaged water systems.

### Max. Pressure/Temperature

Body:	Ryton (PPS)
Electrodes:	316 stainless steel
Insulator:	Polyether-ether ketone (PEEK)
Internal O-rings:	Ethylene propylene
External O-rings:	Buna-N

### Special Features

Twist lock insertion simplifies access.

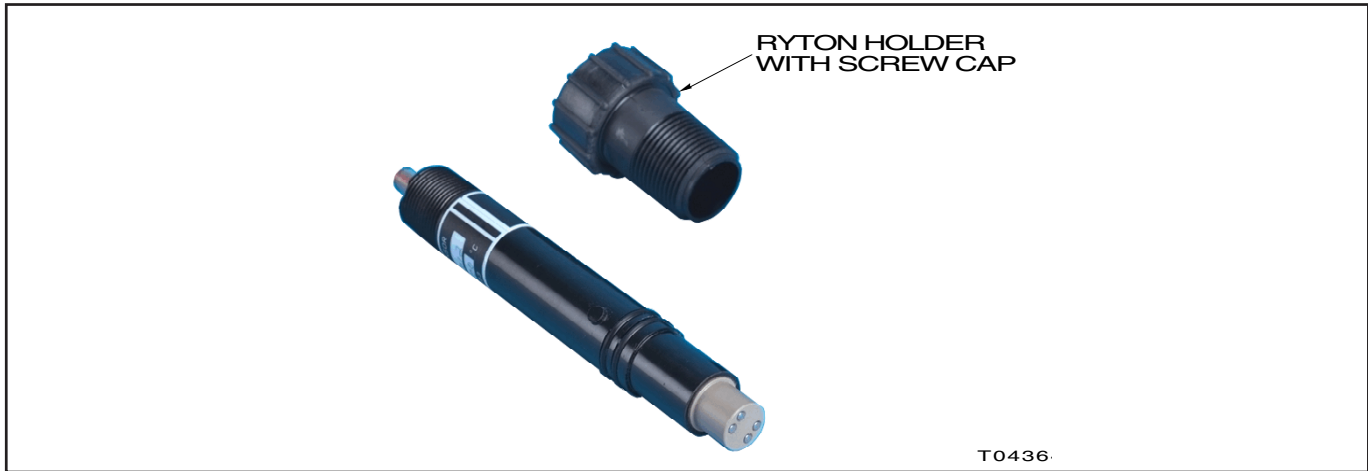

Figure 6. Endura TB454 Sensor

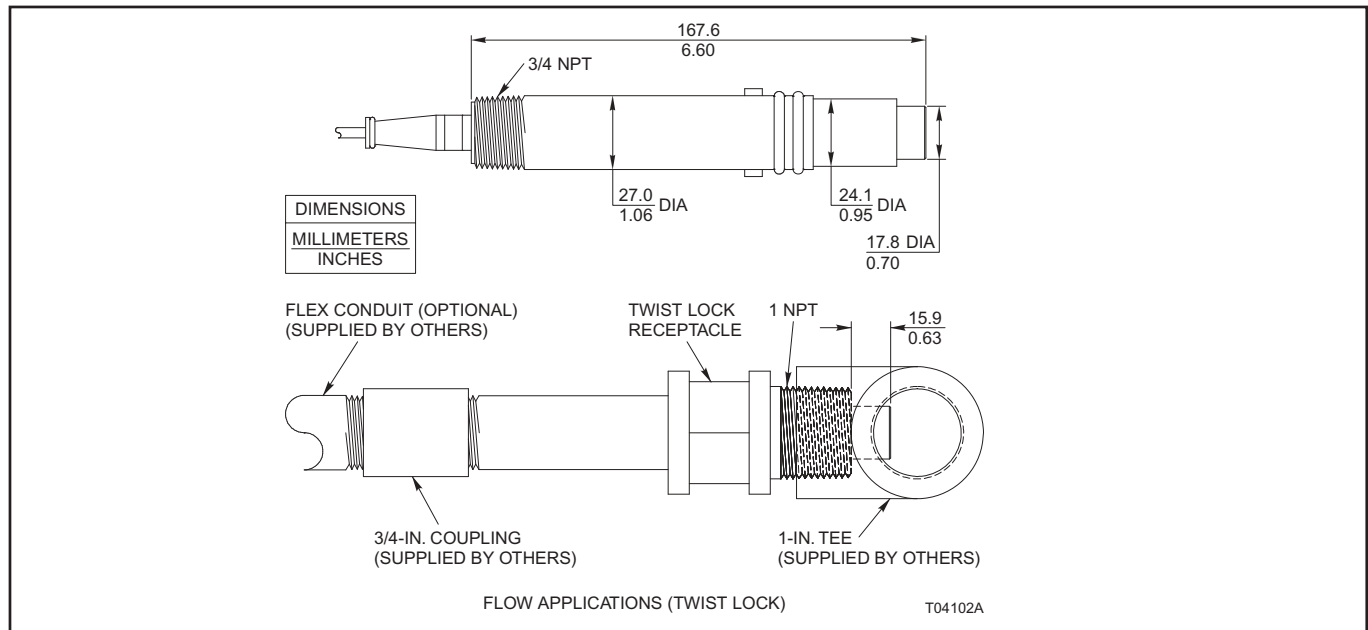

Figure 7. Endura TB454 Sensor Dimensions

	Variant digit No.	1-5	6	7	8	9
<b>Endura TB454 Twist-Lock Conductivity Sensor</b>						
<b>Range 0 - 2,000,000 <math>\mu</math>S/cm</b>	<b>TB454</b>		X	X	X	X
<b>Body Style</b>						
Standard			0			
<b>Integral Temperature Compensation</b>						
3K ohm				E		
<b>Mounting Accessories</b>						
None						0
1 inch NPT 316SS Twist-Lock Receptacle (4TB5205-0118)						2
1 inch NPT Ryton Twist-Lock Receptacle (4TB9515-0120)						3
<b>Integral Cable Length</b>						
No Cable; Junction Box (4TB5023-0088) Included						0
5 ft (1.5 m)						1
10 ft (3 m)						2
15 ft (4.5 m)						3
20 ft (6 m)						4
25 ft (7.6 m)						5
30 ft (9.1 m)						6
35 ft (10.6 m)						7
40 ft (12.1 m)						8
45 ft (13.7 m)						9
50 ft (15.2 m)						A
75 ft (22.9 m)						B
100 ft (30.5 m)						C

**Accessories**

Interconnecting cable (per foot)	4TB3004-0008
Mylar tag	4TB5003-0002
Stainless steel tag	4TB5003-0003
1 inch NPT 316 Stainless steel Twist-Lock Receptacle	4TB5205-0118
1 inch NPT Ryton Twist-Lock Receptacle	4TB9515-0120
Junction box	4TB5023-0088
Cable Grips with reducer for Junction box, 04A-Kit	4TB9515-0244

## Endura TB457 & TB458 Stainless Steel Sterilizable Tri-Clamp Conductivity Sensors

Endura TB457 and TB458 sensors (Figure 8) have 316 stainless steel bodies and integral Tri-clamp fittings for use in applications requiring steam sterilization. The electrode tips and electrodes are sealed with an FDA approved silicon potting material. ABB offers two styles of these sensors, a flush face that meets the process at the Tri-clamp fitting. The second has an extended face designed to place the electrodes into the process past the fitting. The extended face version is narrow enough to allow rinsing chemicals or steam to surround the wetted surfaces to ensure effective cleaning. The Endura TB457 and TB458 sensor specifications are shown to the right and the ordering guide on the next page. Dimensions are shown in Figure 9.

## Endura TB457 & TB458 Sensor Specifications

### Applications

Food, beverage, dairy & pharmaceutical services where process lines must be kept sanitary and /or chemical or steam cleaning takes place.

### Max. Pressure/Temperature

**861 kPag (125 psig) at 175°C (347°F) max.**

### Materials

Body, flange and electrodes:	316 stainless steel
Insulator:	PEEK
Internal O-rings:	Ethylene propylene sealed with FDA approved silicone potting material

### Special Features

Tri-clamp fitting. Wide conductivity range.

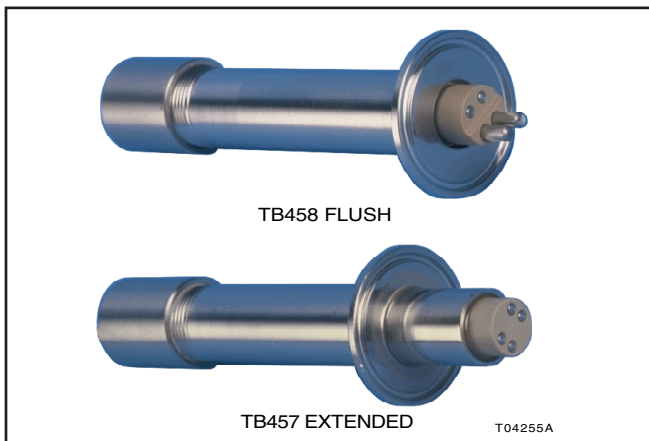

Figure 8. Endura TB457 & TB458 Sensors

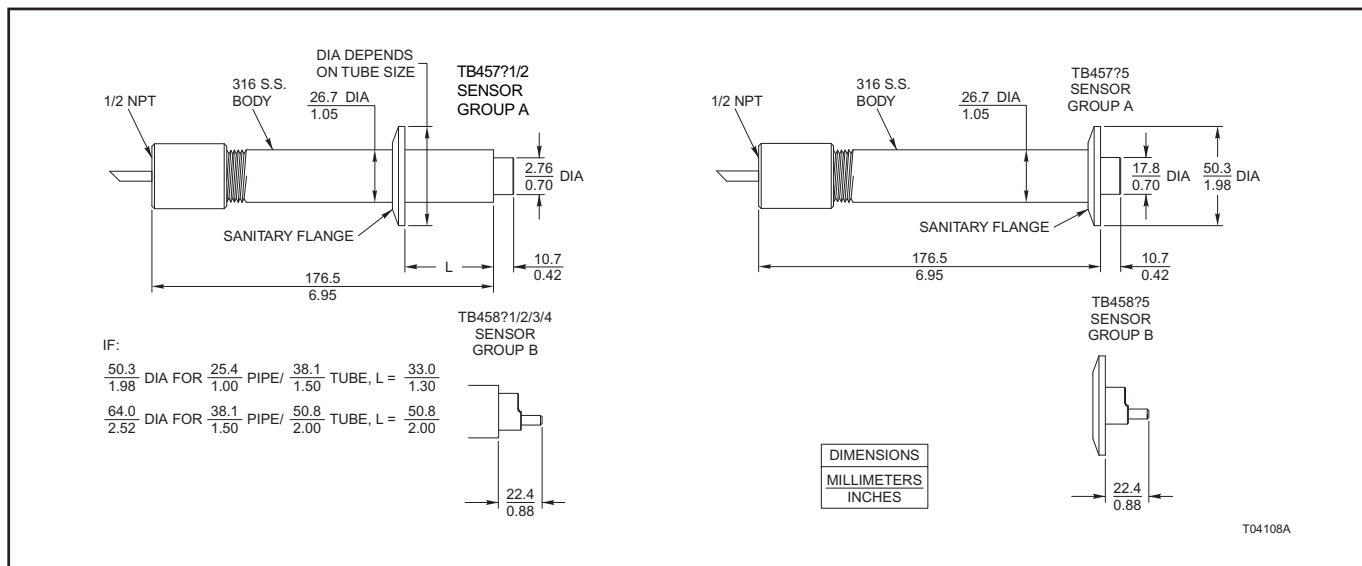

Figure 9. Endura TB457 & TB458 Sensor Dimensions

Variant digit No.	1-5	6	7	8
<b>Endura TB457 Stainless Steel Sterilizable Tri-Clamp Conductivity Sensor</b>				
<b>Range 0 - 2,000,000 <math>\mu</math>S/cm</b>		<b>TB457</b>	X	X
<b>Integral Temperature Compensation</b>				
3K ohm			E	
<b>Tri-Clamp Style</b>				
Extended style, for 1.5 inch tube, 2 inch flange Tri-Clamp				<b>1</b>
Extended style, for 2.0 inch tube, 2.5 inch flange Tri-Clamp				<b>2</b>
Flush style, for 1.0 or 1.5 inch tube, 2 inch flange Tri-Clamp				<b>5</b>
<b>Integral Cable Length</b>				
No Cable; Junction Box (4TB5023-0088) Included				<b>0</b>
5 ft (1.5 m)				<b>1</b>
10 ft (3 m)				<b>2</b>
15 ft (4.5 m)				<b>3</b>
20 ft (6 m)				<b>4</b>
25 ft (7.6 m)				<b>5</b>
30 ft (9.1 m)				<b>6</b>
35 ft (10.6 m)				<b>7</b>
40 ft (12.1 m)				<b>8</b>
45 ft (13.7 m)				<b>9</b>
50 ft (15.2 m)				<b>A</b>
75 ft (22.9 m)				<b>B</b>
100 ft (30.5 m)				<b>C</b>

**Accessories**

Interconnecting cable (per foot)	4TB3004-0008
Mylar tag	4TB5003-0002
Stainless steel tag	4TB5003-0003
Junction box	4TB5023-0088
Cable Grips with reducer for Junction box, 04A-Kit	4TB9515-0244

	Variant digit No.	1-5	6	7	8
<b>Endura TB458 Stainless Steel Sterilizable Tri-Clamp Conductivity Sensor</b>					
<b>Range 0 - 2,000 <math>\mu</math>S/cm</b>	<b>TB458</b>	X	X	X	
<b>Temperature Compensation</b> 3K ohm			E		
<b>Tri-Clamp Style</b>					
Extended style, for 1.5 inch tube, 2 inch flange Tri-Clamp				1	
Extended style, for 2.0 inch tube, 2.5 inch flange Tri-Clamp				2	
Flush style, for 1.0 or 1.5 inch tube, 2 inch flange Tri-Clamp				5	
<b>Integral Cable Length</b>					
No Cable; Junction Box (4TB5023-0088) Included					0
5 ft (1.5 m)					1
10 ft (3 m)					2
15 ft (4.5 m)					3
20 ft (6 m)					4
25 ft (7.6 m)					5
30 ft (9.1 m)					6
35 ft (10.6 m)					7
40 ft (12.1 m)					8
45 ft (13.7 m)					9
50 ft (15.2 m)					A

**Accessories**

Interconnecting cable (per foot)	4TB3004-0008
Mylar tag	4TB5003-0002
Stainless steel tag	4TB5003-0003
Junction box	4TB5023-0088
Cable Grips with reducer for Junction box, 04A-Kit	4TB9515-0244

## Endura TB461 & TB465 Inline, Immersion or Hot Tap (Retractable) Conductivity Sensor

Ruggedly constructed of 316 stainless steel, these sensors withstand the most demanding processes and measurement requirements. Endura TB46 insertion/submersion sensors (Fig. 10) are easily installed into process lines and vessels by the 3/4-NPT insertion threads or immersed directly into fluids by the back-threads. Endura TB46 hot tap sensors (Fig. 10) are directly inserted and removed from lines and vessels without disturbing the process via either a 1 1/2 inch normal or 1 1/4 inch full port ball valve. This series is the most versatile offered by ABB. Full spectrum conductivity measurement is achieved by the wide rangeability of the sensor and the unique interchangeable tip design. The specifications are listed in Table 9 and the ordering guide in Table 10. Dimensions are shown in Figures 11 & 12.

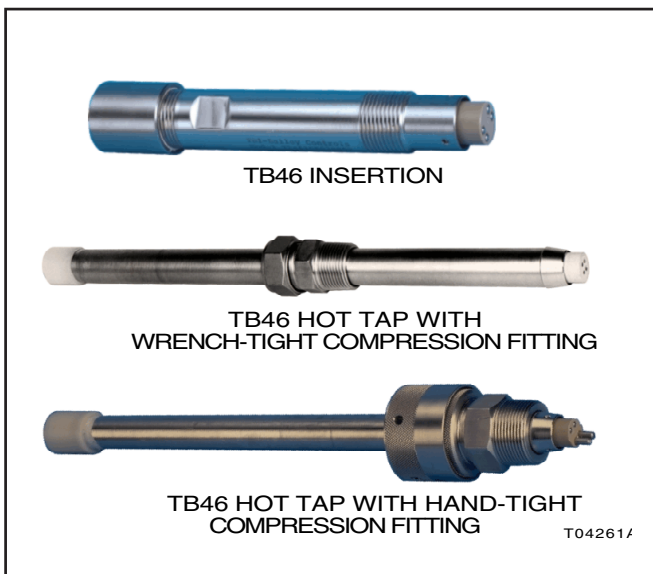

Figure 10. Endura TB461 & TB465 Sensors

## Endura TB46 Sensor Specifications

### Applications (typical)

#### Inline/immersion:

Boiler measurements, sewer monitoring, cooling towers, condensate, deionizers and other water treatment applications, heat exchangers, concentration monitoring, and all other general conductivity measurements.

#### Retractable Hot tap:

Boiler condensate measurements, pulp stock lines, sealed vessel monitoring, and all other general conductivity measurements requiring sensor/insertion/removal without process disturbance.

### Max. Pressure/Temperature:

#### Inline/immersion:

1,550 kPag (225 psig) at  
200°C (392°F)  
1100 psig at 100°F (special request label)

#### Retractable Hot tap:

689 kPag (100psig) at 200°C (392°F) max.

### Materials:

Body, electrodes, compression fittings:  
316 stainless steel  
(compression fittings only)

Insulator: PEEK

O-rings: Ethylene propylene

Compression fitting ferrule:  
Nylon (ball valve insertion only)

### Special Features:

#### Inline/immersion:

Interchangeable and replaceable electrode tips. Direct measurement above 100°C (212°F) without coolers with proper antifeashing installation.

#### Retractable Hot tap:

Interchangeable and replaceable electrode tips. Accidental sensor blowout prevented by antiblowout lip machined into sensor body.

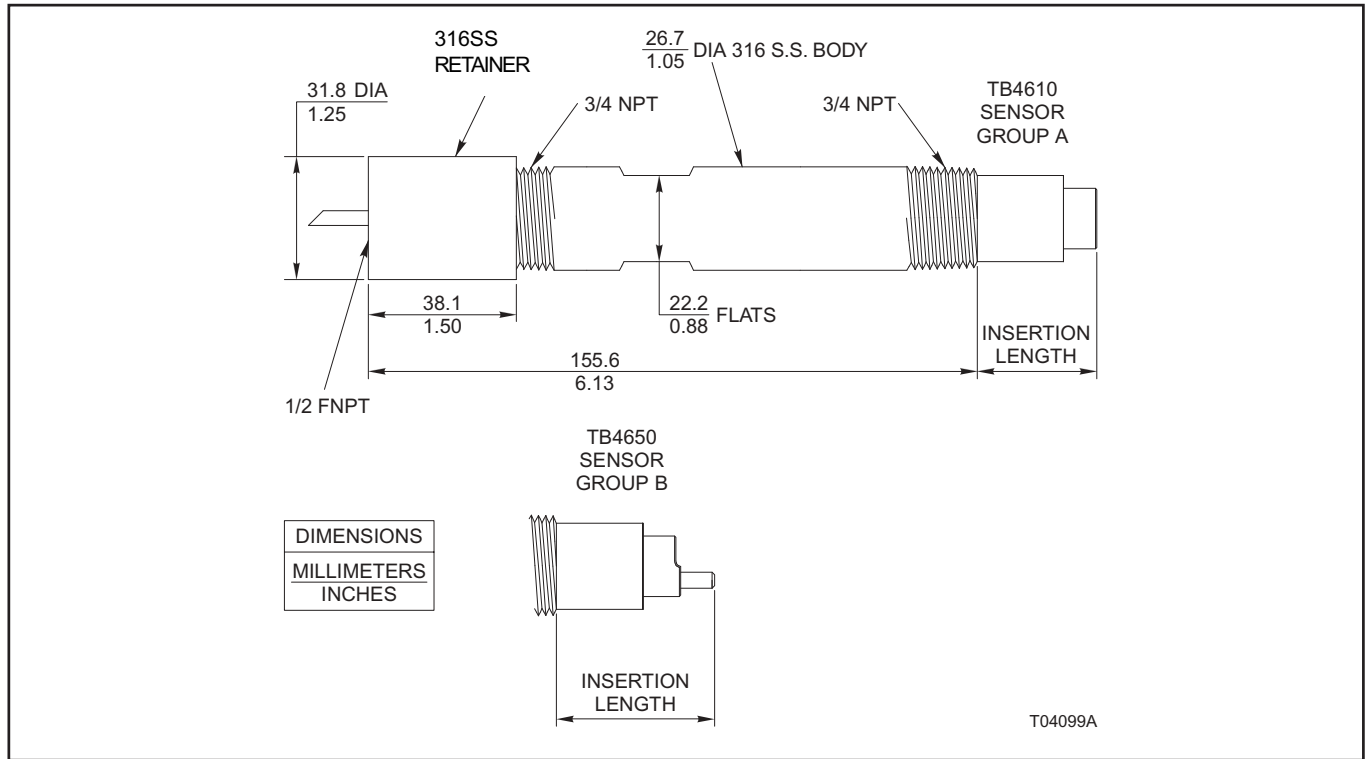

Figure 11. Endura TB46 Inline/Immersion Dimensions

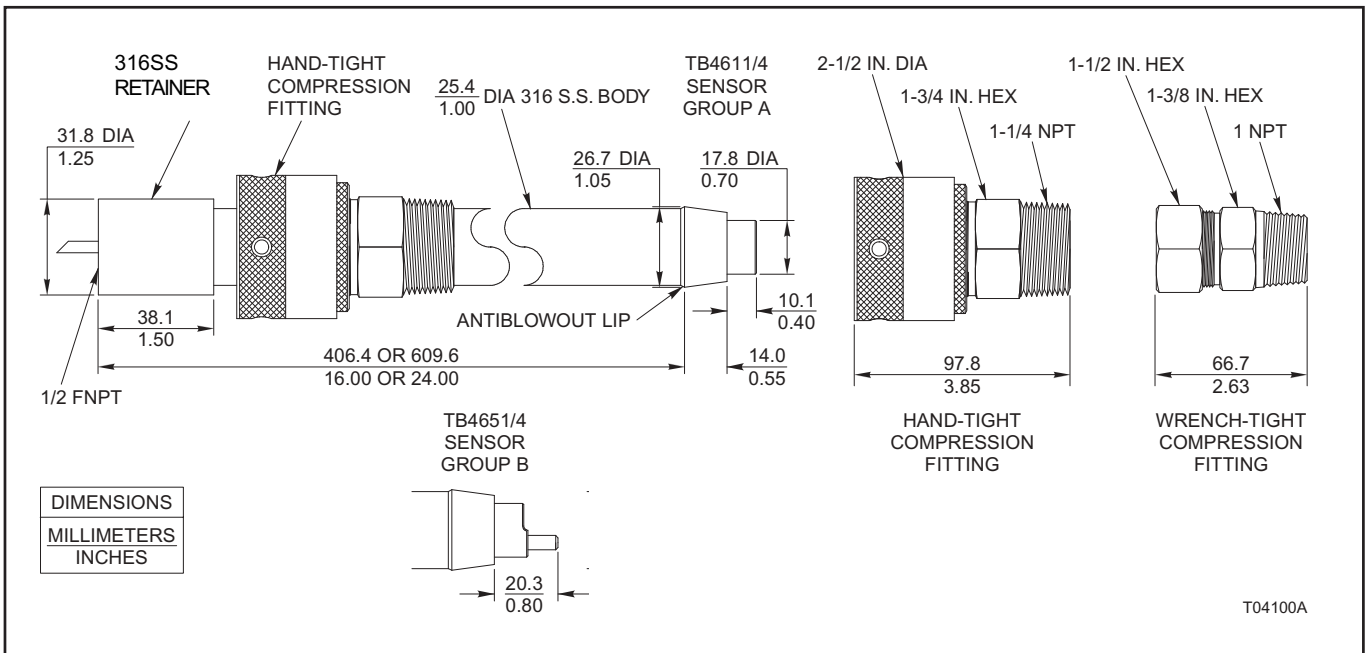

Figure 12. Endura TB46 Hot Tap Dimensions



Variant digit No.						6	7	8	9	10	11	12	13
<b>Endura TB461 Inline, Immersion or Hot Tap (Retractable) Conductivity Sensor</b>													
<b>Range 0 - 2,000,000 µS/cm</b>													
<b>Sensor Style</b>						<b>TB461</b>	X	X	X	X	X	X	X
Inline insertion or Immersible						0							
Hot Tap, No Hardware, 16 inch length						1							
Hot Tap, No Hardware, 24 inch length						4							
Hot Tap, No Hardware, 30 inch length						5							
Hot Tap, No Hardware, 36 inch length						6							
<b>Integral Temperature Compensation</b>													
3K ohm									E				
<b>Hot Tap Mounting Hardware and Compression Fittings</b>													
No hardware (for Inline Insertion and Immersion)									0				
Hand-tight, 316SS, 1.25 inch NPT (for TB461.1/4/5/6 only)									1				
Wrench-tight, 316SS, 1.0 inch NPT (for TB461.1/4/5/6 only)									2				
Flush & Drain housing, Wrench-tight, 316SS, Viton O-ring, 1.5 inch NPT (4TB9515-0084)									B				
Flush & Drain housing, Wrench-tight, 316SS, EPDM O-ring, 1.5 inch NPT (4TB9515-0082)									C				
Flush & Drain housing, Wrench-tight, 316SS, Kalrez O-ring, 1.5 inch NPT (4TB9515-0086)									D				
Flush & Drain housing, Wrench-tight, Titanium, Viton O-ring, 1.5 inch NPT (4TB9515-0060)									F				
Flush & Drain housing, Wrench-tight, Titanium, EPDM O-ring, 1.5 inch NPT (4TB9515-0058)									G				
Flush & Drain housing, Wrench-tight, Titanium, Kalrez O-ring, 1.5 inch NPT (4TB9515-0061)									H				
Flush & Drain housing, Hand-tight, 316SS, Viton O-ring, 1.5 inch NPT (4TB9515-0078)									P				
Flush & Drain housing, Hand-tight, 316SS, EPDM O-ring, 1.5 inch NPT (4TB9515-0076)									Q				
Flush & Drain housing, Hand-tight, 316SS, Kalrez O-ring, 1.5 inch NPT (4TB9515-0080)									R				
Flush & Drain housing, Hand-tight, Titanium, Viton O-ring, 1.5 inch NPT (4TB9515-0063)									T				
Flush & Drain housing, Hand-tight, Titanium, EPDM O-ring, 1.5 inch NPT (4TB9515-0062)									U				
Flush & Drain housing, Hand-tight, Titanium, Kalrez O-ring, 1.5 inch NPT (4TB9515-0064)									V				
<b>Integral Cable Length</b>													
No Cable; Junction Box (4TB5023-0088) Included									0				
5 ft (1.5 m)									1				
10 ft (3 m)									2				
15 ft (4.5 m)									3				
20 ft (6 m)									4				
25 ft (7.6 m)									5				
30 ft (9.1 m)									6				
35 ft (10.6 m)									7				
40 ft (12.1 m)									8				
45 ft (13.7 m)									9				
50 ft (15.2 m)									A				
75 ft (22.9 m)									B				
100 ft (30.5 m)									C				
<b>Additional Insertion Length for Inline Insertion Style</b>													
Standard Length (1.25 inch), for Hot Tap sensor style TB461.1/4/5/6									3) 4)	0	0	0	
2.0 inch (for TB461.0 Inline Insertion only)									3)	2	.	0	
3.0 inch (for TB461.0 Inline Insertion only)									3)	3	.	0	
4.0 inch (for TB461.0 Inline Insertion only)									3)	4	.	0	
5.0 inch (for TB461.0 Inline Insertion only)									3)	5	.	0	
6.0 inch (for TB461.0 Inline Insertion only)									3)	6	.	0	
7.0 inch (for TB461.0 Inline Insertion only)									3)	7	.	0	
<b>Insulator Tip Material</b>													
PEEK													2

3) Distance measured from end of threads to tip of electrodes.

4) This is the default standard insertion length for Inline Insertion style.

Endura TB461 continued:

**Accessories**

Interconnecting cable (per foot)	4TB3004-0008
Mylar tag	4TB5003-0002
Stainless steel tag	4TB5003-0003
Junction box	4TB5023-0088
316 Stainless steel 1.25 inch Ball Valve assembly kit with Wrench-tight compression fittings	4TB5205-0174
316 Stainless steel 1.25 inch Ball Valve assembly kit with Hand-tight compression fittings	4TB5205-0217
316 Stainless steel 1.5 inch Ball Valve assembly kit with Wrench-tight compression fittings	4TB5205-0255
316 Stainless steel 1.5 inch Ball Valve assembly kit with Hand-tight compression fittings	4TB5205-0254
Cable Grips with reducer for Junction box, 04A-Kit	4TB9515-0244

Variant digit No.						1-5	6	7	8	9	10	11	12	13
<b>Endura TB465 Inline, Immersion or Hot Tap (Retractable) Conductivity Sensor</b>														
<b>Range 0 - 2,000 µS/cm</b>						<b>TB465</b>	X	X	X	X	X	X	X	X
<b>Sensor Style</b>														
Inline insertion or Immersible							0							
Hot Tap, No Hardware, 16 inch length							1							
Hot Tap, No Hardware, 24 inch length							4							
Hot Tap, No Hardware, 30 inch length							5							
Hot Tap, No Hardware, 36 inch length							6							
<b>Integral Temperature Compensation</b>														
3K ohm									E					
<b>Hot Tap Mounting Hardware and Compression Fittings</b>														
No hardware (for Inline Insertion and Immersion)									0					
Hand-tight, 316SS, 1.25 inch NPT (for TB465.1/4/5/6 only)									1					
Wrench-tight, 316SS, 1.0 inch NPT (for TB465.1/4/5/6 only)									2					
Flush & Drain housing, Wrench-tight, 316SS, Viton O-ring, 1.5 inch NPT (4TB9515-0084)									B					
Flush & Drain housing, Wrench-tight, 316SS, EPDM O-ring, 1.5 inch NPT (4TB9515-0082)									C					
Flush & Drain housing, Wrench-tight, 316SS, Kalrez O-ring, 1.5 inch NPT (4TB9515-0086)									D					
Flush & Drain housing, Wrench-tight, Titanium, Viton O-ring, 1.5 inch NPT (4TB9515-0060)									F					
Flush & Drain housing, Wrench-tight, Titanium, EPDM O-ring, 1.5 inch NPT (4TB9515-0058)									G					
Flush & Drain housing, Wrench-tight, Titanium, Kalrez O-ring, 1.5 inch NPT (4TB9515-0061)									H					
Flush & Drain housing, Hand-tight, 316SS, Viton O-ring, 1.5 inch NPT (4TB9515-0078)									P					
Flush & Drain housing, Hand-tight, 316SS, EPDM O-ring, 1.5 inch NPT (4TB9515-0076)									Q					
Flush & Drain housing, Hand-tight, 316SS, Kalrez O-ring, 1.5 inch NPT (4TB9515-0080)									R					
Flush & Drain housing, Hand-tight, Titanium, Viton O-ring, 1.5 inch NPT (4TB9515-0063)									T					
Flush & Drain housing, Hand-tight, Titanium, EPDM O-ring, 1.5 inch NPT (4TB9515-0062)									U					
Flush & Drain housing, Hand-tight, Titanium, Kalrez O-ring, 1.5 inch NPT (4TB9515-0064)									V					
<b>Integral Cable Length</b>														
No Cable; Junction Box (4TB5023-0088) Included										0				
5 ft (1.5 m)										1				
10 ft (3 m)										2				
15 ft (4.5 m)										3				
20 ft (6 m)										4				
25 ft (7.6 m)										5				
30 ft (9.1 m)										6				
35 ft (10.6 m)										7				
40 ft (12.1 m)										8				
45 ft (13.7 m)										9				
50 ft (15.2 m)										A				
<b>Additional Insertion Length for Inline Insertion Style</b>														
Standard Length (1.25 inch), for Hot Tap sensor style TB465.1/4/5/6									3) 4)	0	0	0		
2.5 inch (for TB465.0 Inline Insertion only)									3)	2	.	5		
3.5 inch (for TB465.0 Inline Insertion only)									3)	3	.	5		
4.5 inch (for TB465.0 Inline Insertion only)									3)	4	.	5		
5.5 inch (for TB465.0 Inline Insertion only)									3)	5	.	5		
6.5 inch (for TB465.0 Inline Insertion only)									3)	6	.	5		
7.5 inch (for TB465.0 Inline Insertion only)									3)	7	.	5		
<b>Insulator Tip Material</b>														
PEEK														2

3) Distance measured from end of threads to tip of electrodes.

4) This is the default standard insertion length for Inline Insertion style.

Endura TB465 continued:

**Accessories**

Interconnecting cable (per foot)	4TB3004-0008
Mylar tag	4TB5003-0002
Stainless steel tag	4TB5003-0003
Junction box	4TB5023-0088
316 Stainless steel 1.25 inch Ball Valve assembly kit with Wrench-tight compression fittings	4TB5205-0174
316 Stainless steel 1.25 inch Ball Valve assembly kit with Hand-tight compression fittings	4TB5205-0217
316 Stainless steel 1.5 inch Ball Valve assembly kit with Wrench-tight compression fittings	4TB5205-0255
316 Stainless steel 1.5 inch Ball Valve assembly kit with Hand-tight compression fittings	4TB5205-0254
Cable Grips with reducer for Junction box, 04A-Kit	4TB9515-0244

**Endura TB464 Flow-cell or Safe-T-Clean Conductivity Sensor**

Endura TB464 sensors (Fig. 13) are available with a bushing nut and union or can be retro-fitted into standard DN25 bushings with 0.983-inch to 0.995-inch internal diameters. They are also available for installation into 4TB9515-0190 and 4TB9515-0223 flow cells or the Endura TB18 Safe-T-Clean sensor valve. It quickly and easily installs into the flow cell without twisting the sensor cable.

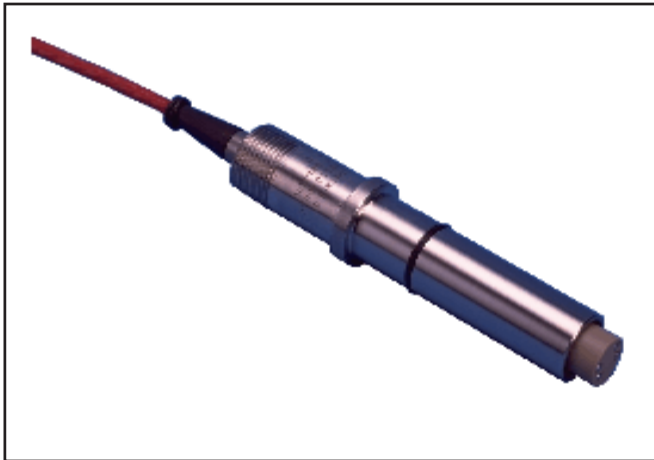

**Figure 13.** Endura TB464 Sensor

**Table 12.** Endura TB464 Sensor Specifications

**Application**

cooling towers, packaged water systems, exchange columns, heat exchangers, all other low to medium range conductivity measurements.

**Max. Pressure/Temperature**

1,378 kPag (200 psig) at 200°C (392°F) max.

**Materials**

Body and electrodes: 316 stainless steel  
Insulator: PEEK  
O-rings: Ethylene propylene

**Special Features**

Easy installation into either flow cell, any available 25-mm port, or the Endura TB18 Safe-T-Clean sensor valve. Flexible insertion depth.

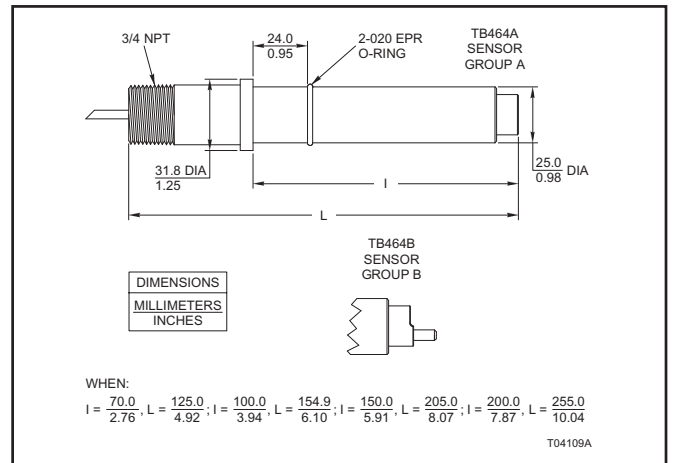

**Figure 14.** Endura TB464 Sensor Dimensions

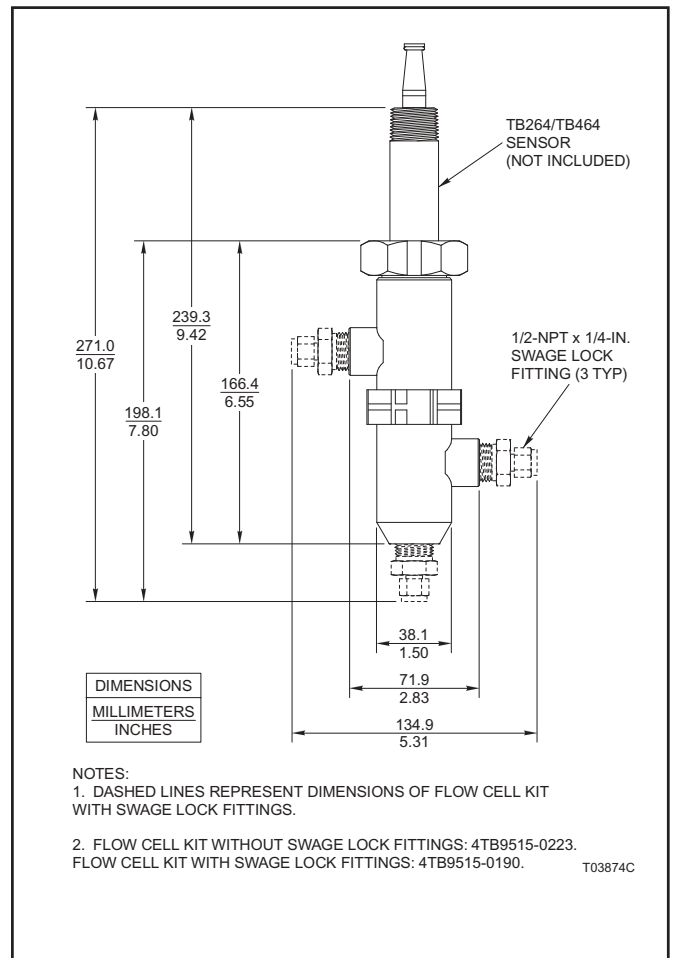

**Figure 14a.** Endura TB464 Flow Cell Kits

Variant digit No.	1-5	6	7	8	9	10	11	12
<b>Endura TB464 Flow-cell and Safe-T-Clean Conductivity Sensor</b> <b>Ranges 0 - 2,000 µS/cm and 0 - 2,000,000 µS/cm</b>		<b>TB464</b>		X	X	X	X	X
<b>Measurement Range</b> A Range, (0 - 2,000,000 µS/cm) B Range, (0 - 2,000 µS/cm)		A B						
<b>Integral Temperature Compensation</b> 3K ohm		E						
<b>O-Ring Material</b> EPR, Standard		1						
<b>Electrode Material</b> 316 Stainless steel				1				
<b>Reserved</b> Reserved for future use						0		
<b>Integral Cable Length</b> No Cable; Junction Box (4TB5023-0088) Included								0
5 ft (1.5 m)								1
10 ft (3 m)								2
15 ft (4.5 m)								3
20 ft (6 m)								4
25 ft (7.6 m)								5
30 ft (9.1 m)								6
35 ft (10.6 m)								7
40 ft (12.1 m)								8
45 ft (13.7 m)								9
50 ft (15.2 m)								A
75 ft (22.9 m) - (Only on A-Range, 0 - 2,000,000 µS/cm)						2)		B
100 ft (30.5 m) - (Only on A-Range, 0 - 2,000,000 µS/cm)						2)		C
<b>Insulator Material</b> PEEK								2

2) Available only on A-Range (0 - 2,000,000 µS/cm) configuration

**Accessories**

Interconnecting cable (per foot)	4TB3004-0008
Mylar tag	4TB5003-0002
Stainless steel tag	4TB5003-0003
Junction box	4TB5023-0088
Cap nut	4TB5101-0474
Flowcell Assembly with 0.25 inch Swagelok connections	4TB9515-0190
Flowcell Assembly with 0.5 inch NPT flow connections	4TB9515-0223
Cable Grips with reducer for Junction box, 04A-Kit	4TB9515-0244

**Endura TB468 Insertion or Hot Tap Conductivity Sensor with Hastelloy Electrodes for Corrosive Service (Group A)**

Endura TB468 sensors are available in either inline insertion (TB4680) (Fig. 15) or hot tap styles (TB4683). The insertion style is also submersible. A Kynar (PVDF) body and Hastelloy® C electrodes allow use in aggressive applications where 316 stainless steel is not advised. The specifications are listed in Table 14 and the ordering guide in Table 15. Endura TB4680 insertion style sensor dimensions are shown in Figure 16 and Endura TB4683 hot tap style sensor dimensions are shown in Figure 17.

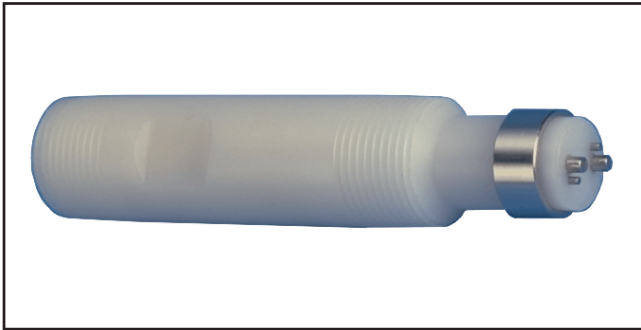

**Figure 15.** Endura TB4680 Sensor

**Endura TB468 Sensor Specifications**

**Applications** (typical)

Concentration monitoring of process streams that would corrode 316 stainless steel electrodes. Condensate and heat exchanger monitoring with potential for acid intrusion.

**Max. Pressure/Temperature**

TB4680:	Max. 689 kPag (100 psig) at 50°C (122°F),
Inline/Immersion	354 kPag (50 psig) at 100°C (212°F) max.
TB4683:	Max. 275 kPag (40 psig) at 90°C (194°F)
Hot-Tap	138 kPag (20 psig) at 140°C (284°F) max.

**Materials**

Body:	Kynar (PVDF)
Hot tap sheath, pressure ring, electrodes:	Hastelloy C
Hot tap compression fitting:	PTFE

**Special Features**

Corrosion resistance.  
Hastelloy Electrodes

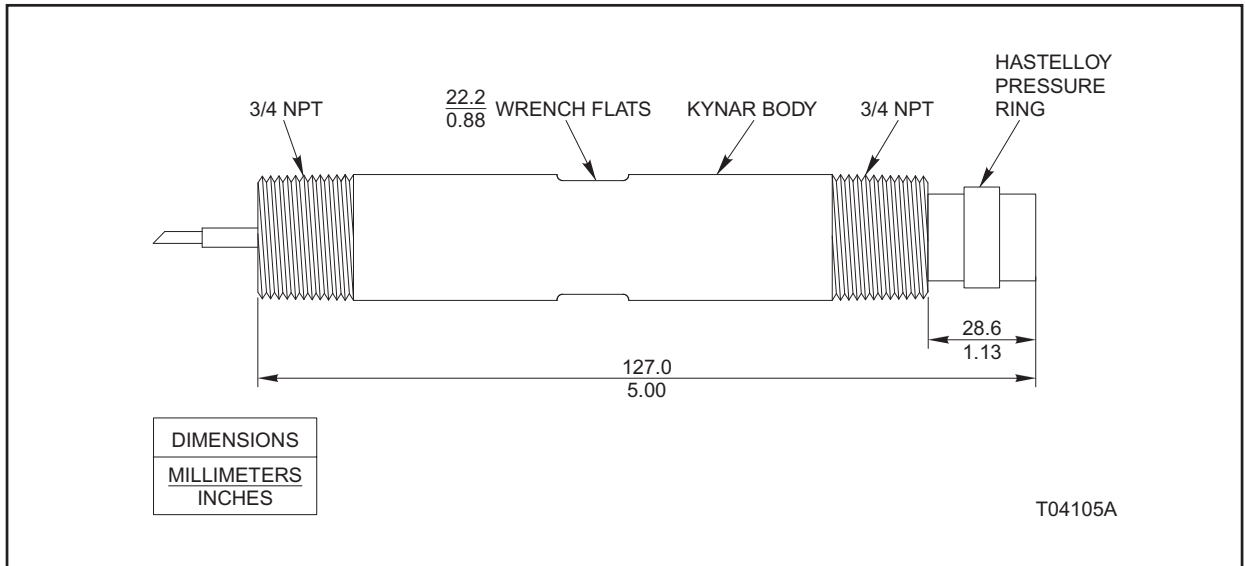

**Figure 16.** Endura TB4680 Insertion Style Dimensions

Variant digit No.	1-5	6	7	8	9
<b>Endura TB468 Inline or Hot Tap Conductivity Sensor with Hastelloy Electrodes for Corrosive Service</b>					
<b>Range 0 - 2,000,000 µS/cm</b>	<b>TB468</b>	X	X	X	X
<b>Sensor Type</b> Insertion or Immersion, limits 50 psi @ 100C - 100 psi @ 50C Retractable Hot Tap, limits 20psi @ 110C - 40psi @ 90C		1) 0			
<b>Integral Temperature Compensation</b> 3K ohm			E		
<b>Mounting Accessories</b> None PTFE Compression Hardware for Retractable Hot Tap only				0 3) 1	
<b>Integral Cable Length</b> No Cable; Junction Box (4TB5023-0088) Included					0
5 ft (1.5 m)					1
10 ft (3 m)					2
15 ft (4.5 m)					3
20 ft (6 m)					4
25 ft (7.6 m)					5
30 ft (9.1 m)					6
35 ft (10.6 m)					7
40 ft (12.1 m)					8
45 ft (13.7 m)					9
50 ft (15.2 m)					A
75 ft (22.9 m)					B
100 ft (30.5 m)					C

1) Does not include ball valve

3) Not available with Sensor Type 0 (Insertion or Immersion)

**Accessories**

Interconnecting cable (per foot)	4TB3004-0008
Mylar tag	4TB5003-0002
Stainless steel tag	4TB5003-0003
Junction box	4TB5023-0088
PTFE Compression Hardware	4TB4953-0074
Kynar ball valve kit for TB468 (1.5 inch ball valve assembly)	4TB5205-0185
Cable Grips with reducer for Junction box, 04A-Kit	4TB9515-0244



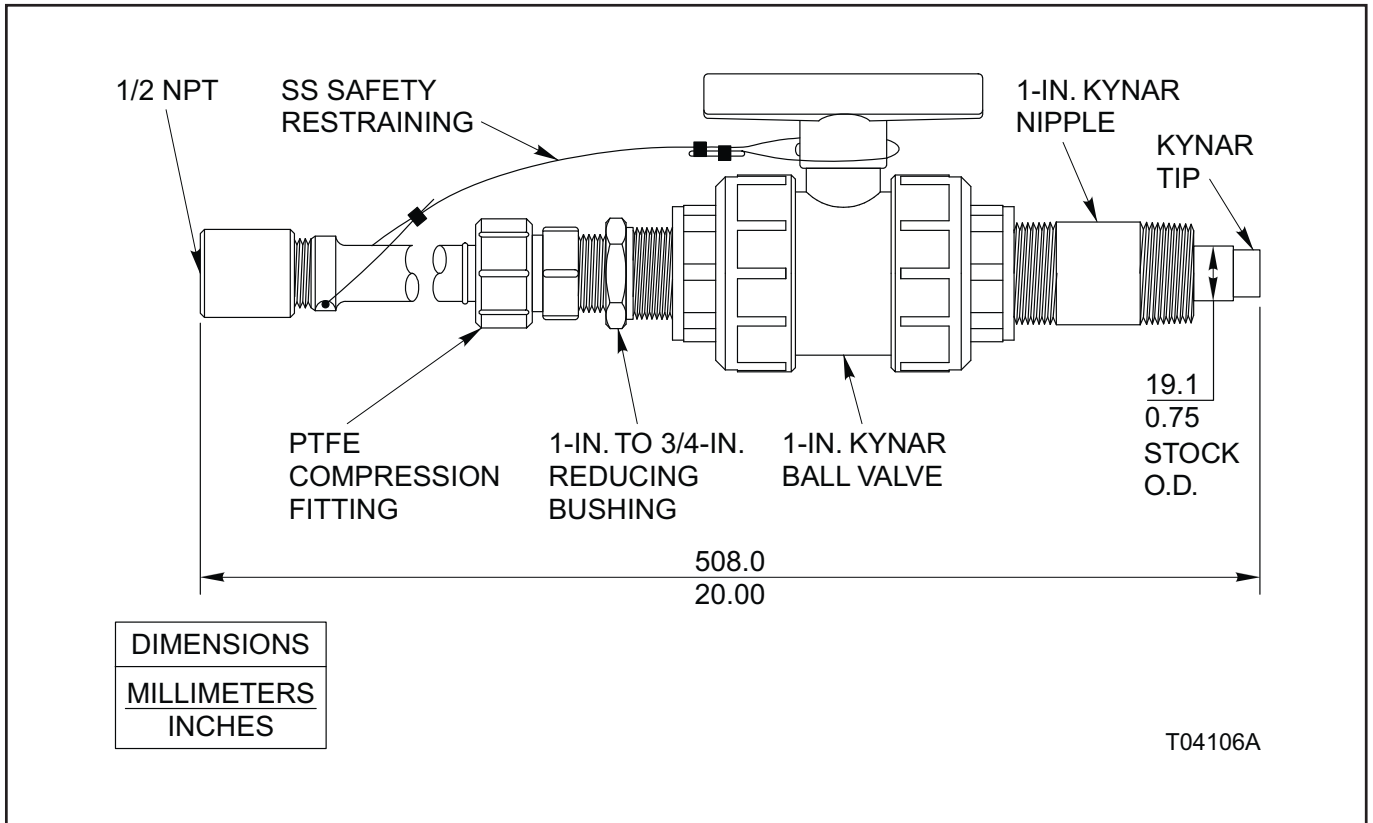

Figure 17. Endura TB4683 Hot Tap Style Dimensions

## Endura TB47 High Pressure Retractable Hot Tap Sensor

Endura TB47 sensors (Fig. 18) can be directly inserted into or removed from lines and vessels without disturbing the process. Designed for service in systems exceeding pressure ranges of standard hot tap sensors, these high pressure hot tap sensors also insure worker safety. Closing a ball valve isolates an extraction housing, separating the operator from the sensor and process. The housing can be pressurized or depressurized and purged by installing flush and/or drain lines to the 1/4-NPT purge connections. Ruggedly constructed of 316 stainless steel, these sensors withstand the most demanding processes and measurement requirements. The specifications are listed in Table 16 and the ordering guide in Table 17. Dimensions are shown in Figure 19.

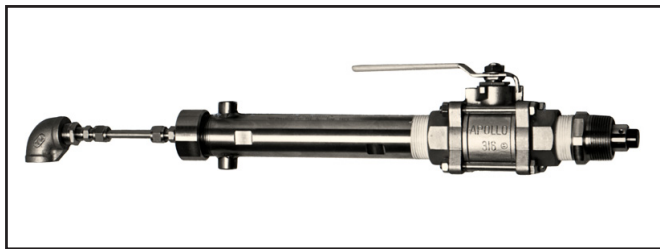

Figure 18. Endura TB471 Sensor

## Endura TB47 Sensor Specifications

### Applications

Boiler condensate measurements, pulp stock lines, sealed vessel monitoring, pulp liquor, toxic chemical monitoring, heat exchangers, concentration monitoring, and other conductivity measurements requiring special worker safety considerations.

### Max. Pressure/Temperature

2,068 kPag (300 psig) at max. temp. of 200°C (392°F)

### Materials

Sensor and valve bodies, electrodes, extraction housing, insertion/body assembly, compression fitting:

	316 stainless steel
Insulator:	PEEK
O-rings:	Ethylene propylene
Compression fitting ferrule:	Kynar (PVDF)
Ball valve seats:	TFE

### Special Features

High pressure capability. Purgeable sensor extraction housing.

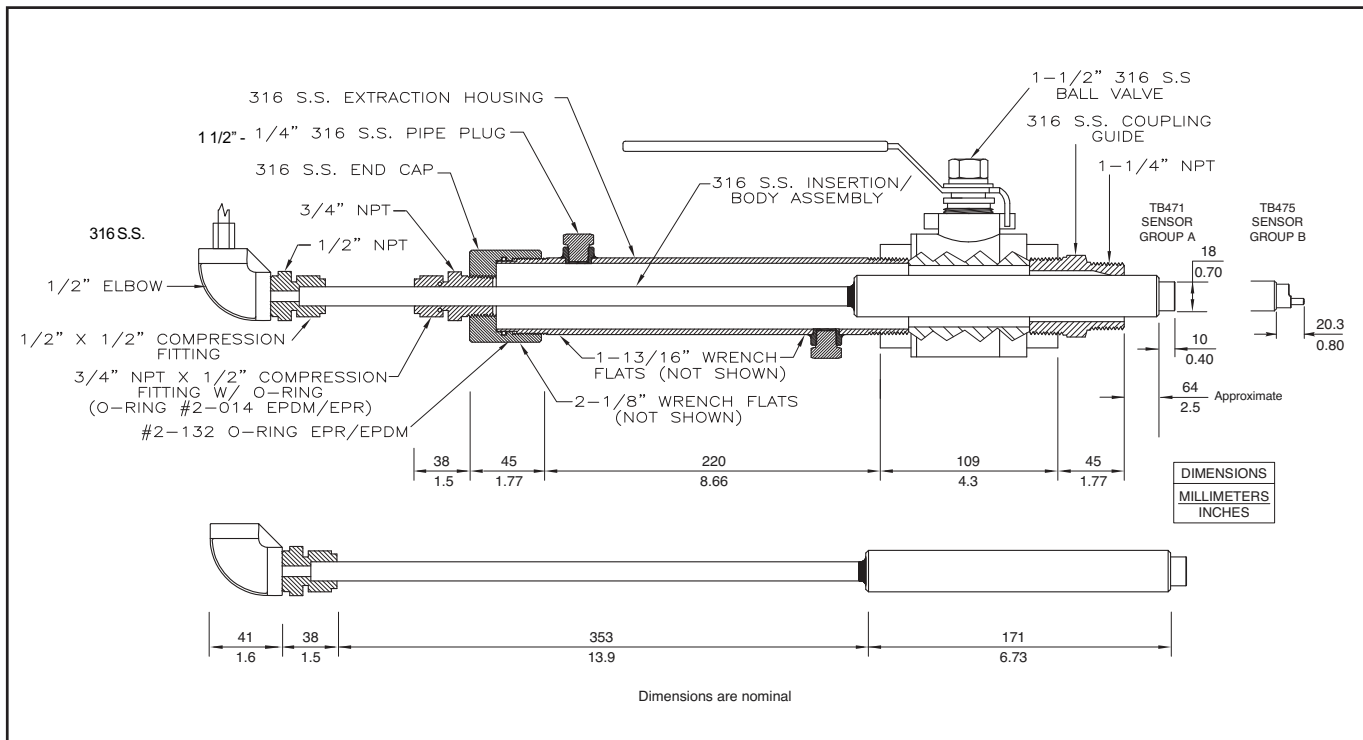

Figure 19. Endura TB47 Sensor Dimensions

		Variant digit No.		1-4	5	6	7	8	9
<b>Endura TB47 High Pressure Retractable Hot Tap Conductivity Sensor</b>									
<b>Ranges 0 - 2,000 µS/cm and 0 - 2,000,000 µS/cm</b>		<b>TB47</b>			X	X	X	X	X
<b>Measurement Range</b>					A				
A Range, (0 - 2,000,000 µS/cm)					B				
B Range, (0 - 2,000 µS/cm)									
<b>Hot Tap Material</b>						6			
316 Stainless steel AISI (1.4401) Assembly, 300 psi @ 200C, PEEK insulator									
<b>Integral Temperature Compensation</b>							E		
3K ohm									
<b>Mounting Accessories</b>								0	
Complete Assembly, include 1.5 inch Ball Valve and Flush & Drain Extraction housing								6	
Basic TB47 Sensor and Flush & Drain Extraction housing, without Ball Valve								7	
Basic TB47 Sensor, without Ball Valve and without Flush & Drain Extraction housing									
<b>Integral Cable Length</b>									0
No Cable; Junction Box (4TB5023-0088) Included									1
5 ft (1.5 m)									2
10 ft (3 m)									3
15 ft (4.5 m)									4
20 ft (6 m)									5
25 ft (7.6 m)									6
30 ft (9.1 m)									7
35 ft (10.6 m)									8
40 ft (12.1 m)									9
45 ft (13.7 m)									A
50 ft (15.2 m)									B
75 ft (22.9 m) - (Only on A-Range, 0 - 2,000,000 µS/cm, TB471 configuration)								2)	C
100 ft (30.5 m) - (Only on A-Range, 0 - 2,000,000 µS/cm, TB471 configuration)								2)	

2) Available only on A-Range (0 - 2,000,000 µS/cm) configuration

#### Accessories

Interconnecting cable (per foot)	4TB3004-0008
Mylar tag	4TB5003-0002
Stainless steel tag	4TB5003-0003
Junction box	4TB5023-0088
316 Stainless steel 1.5 inch Ball Valve assembly with Wrench-tight fittings	4TB5205-0255
TB47 Flush & Drain Extraction housing	4TB5101-0504
Cable Grips with reducer for Junction box, 04A-Kit	4TB9515-0244